

TRACTOR PULLING CONTEST
ONLY 1 PERSON (DRIVER) ON TRACTOR AT
ANY TIME

Co - Chairmen -- Roger Dibble, Ed Rossley

COMMITTEE:

Mike Bowker, Brian Gladding, Rob LaTourette, Bob Moody, Gerry Ruestow, Vic Stevens, Allan VanBuren, Jay VanBuren, Sean Trimbell, Ed Docskalic, Jason Craig, Bruce Bennett, ChrisVoorhies, and Eric Bowker, Ken Reynolds, Cecil Davis, Adam Robertson

In order to promote a knowledge of tractor capacities, show safety in tractor operation, demonstrate tractor driving skill and good judgment while hauling heavy loads, the committee members and directors of the Delaware Valley Agricultural Society have established the following rules and classes of competition for the tractor pulling contest.

GENERAL RULES

1. All contestants must be 8 years of age to 5 for stock garden tractor (under 12 must be accompanied on the track by parent or guardian), 12 years for super stock and modified garden tractor and 16 years for farm tractor classes unless certificated driver.
2. Entry fees will be \$5.00 for garden tractors and \$15.00 for farm tractors. Dealers may pay entry fee and enter for exhibition purposes only.
3. Entrants will draw for position at the time of registration. Registration will be closed for each class at the start of that class.
4. All contestants must sign an agreement of release, relieving the fair association of any liability in case of accident.
5. No driver will be allowed to participate while under the influence of alcohol, drugs or medications. Any unsportsmanlike conduct may result in disqualification..
6. Operators must be fully clothed, including shoes and no flip flops.
7. Tractors will be classified according to weight. All units will be weighed with operators on the tractor. No driver changes allowed.
8. All starts must be made from a tight chain. No jerking starts allowed.
9. Only the operator will be allowed on the tractor. The driver must remain seated with one hand on the wheel during the pull and feet remaining on the running board or pegs.
10. Tractors will be weighed with drivers immediately

before the pull. Drivers will be responsible for having tractor within weight limit.

11. All tractors must have rubber tires and use two-wheel drive. Dual tires or tire chains are prohibited.
12. No loose weights or protruding bolts allowed. Wheel weight bolts must not extend more than 3" past weights or tire, whichever is most outward. Any ballast lost while hooked to the sled will be cause for disqualification.
13. All tractors must have operational brakes.
14. No pressurized fuels or oxidizers allowed in any class.
15. Pulls will be made using a transfer sled. Number one puller shall be the test puller, he may take the pull or re-pull in third position after the following two pullers or re-pull in last place.
16. If breakage or malfunction of a tractor occurs, the official distance will be where the transfer sled stops.
17. Tractors which go out of bounds will be disqualified.
18. An elimination pull will be scheduled in the event of any ties. Pull-off contestants will be allowed only one attempt. In case of pull-off, tire changes will not be allowed.
19. Tractors weighing more than the class limit will not be allowed to pull.
20. All rules will be strictly enforced. Decisions of the judges are final.
21. No part of the tractor may interfere with hook up to the sled.

GARDEN TRACTOR RULES

1. Each contestant will be allowed two attempts or 10 feet to start the sled in turf class and 30' for the rest of classes. The track will be 15 feet wide and 150 feet long for 8/10/12/16 Horse power Classes and 15' wide/200 ft long for 20 hp and stock altered classes.
2. Wheelie bars are mandatory on all tractors. Any tractor without them will not be allowed to pull. These must be no more than 6" to 5" off the ground and no less than 5" behind the rear of the tires.
3. The drawbar must be stationary in all directions, shall be no higher than 13", and not extend beyond the rear tires.
4. Drivers must supply their own clevis or hitch ring with at least a 1 1/2" diameter hole.
5. No turbo chargers or blowers are allowed in any class, except super stock and modified diesels.
6. Engine exhaust must discharge vertically upward, excluding stock tractors with mufflers in place.

7. Tractors may have turf tires or bar-type tires - no paddle tires allowed.
8. 1/16" metal shields must be provided over drive belts, chains and around fans.
9. 1/8" metal shields must be provided 360° around flywheels and clutches.
10. 1/8" metal shields must be provided over turbochargers.
11. A kill switch must be provided at the rear of the tractor with a 1" minimum diameter ring for connection to the sled, with the exception of stock tractors.
12. All entrants 16 and under must wear helmets (all classes).
13. Two hooks per tractor only! Either 2 different drivers in one class or one in 2 classes.
14. All Tractors will be weighed after hook and hitch measured

STOCK TRACTORS RULES:

1. Tractors must be commercially made and must be stock!
2. Maximum tire size is 26 x 12 x 12. If originally equipped with 16" rims, maximum tire size is 8.50 x 16".
3. In Class 1 (850 lbs., 8 hp) turf tires ONLY may be used. Turf tires in this class may not be cut or sharpened.
4. Tractors may rev no more than 4000 rpm at wide open throttle.
5. 16 & 20 hp – Stock may run 4500 rpm
6. Tractors must have air cleaners.
7. No professional pulling tires allowed.

SUPER STOCK TRACTORS RULES:

1. Tractors must be stock in appearance and must have hood, grill and seat in place.
2. Tractor frame may be modified, but not lengthened.
3. Transmission and rear axle housings must be stock though interior parts may be modified.
4. Engine must be 1 or 2 cylinder, 4 cycle and originally made for use in a garden tractor at 20 hp. or less. Internal modifications are allowed. 50.5 cubic inch maximum.
5. Maximum tire size is 26 x 12 x 12.
6. Drivers must wear a D.O.T. approved helmet.

7. Gas or alcohol is allowed for fuel. No additives will be allowed.

STOCK ALTERED RULES:

1. Tractors must be stock in appearance and must have hood, grill and seat in place.
2. Transmission and rear axle housings must be stock though interior parts may be modified.
3. Engine must be 1 cylinder, 4 cycle and originally made for use in a garden tractor at 16 hp., or less.
4. Maximum tire size is 26 x 12 x 12.
5. Commercially available, cast block engine. Typical manufacturers would be Kohler, Tecumseh, Wisconsin, etc.
6. Engine must maintain stock appearance.
7. Chassis may be altered to accept non-original engine, however, the wheelbase may be extended to 52" max. Maximum length of tractor is 7 foot from centerline of rear axel forward.
8. Polishing and porting is to be allowed.
9. Non-stock camshaft is allowed.
10. Must utilize stock style carburetion system with 1.000 diameter venturi.
11. Must utilize stock ignition system.
12. Pump gasoline or diesel or alcohol only. No additives. no nitromethane, no nitrous oxide, no pressurized fuel tanks.
13. Maximum crankshaft stroke 3.25", maximum engine bore 3.780", 36.5000 cubic inch limit.
14. Maximum engine valve size 1.380", maximum engine valve lift .330".
15. Built heads are permitted, porting and polishing are allowed.
16. No external welding or external modifications allowed. Welding is permitted in crankcase area of the block for repair.

GARDEN TRACTOR CLASSES

The Garden Tractor Pull will be held at 8:30 a.m. sharp Monday of the Fair. Sign-up starts at 7:30 a.m.

<u>Length</u>	<u>Track</u>
Class 1 - 850 lbs., 8 hp. Stock - turf tires	150
Class 2 - 1050 lbs., 10 hp Stock	150
Class 3 - 1050 lbs., Stock Altered	200
Class 4 - 1050 lbs., 16 hp stock 4500 rpm	150
Class 5 - 1050 lbs., up to 20 hp Stock 4500 rpm	200
Class 6 - 1050 lbs., Super Stock	200
Class 7 - 1050lbs., Sport Stock	200
Class 8 - 900 lbs., 8 hp Ag Tires	150
Class 9 - 1050 lbs., 12 hp Ag Tires	150
Class 10 - 1100 lbs., Stock Altered	200
Class 11 - 1100 lbs., 10 hp. Ag Tires	150
Class 12 - 1100 lbs., 16 hp stock 4500 rpm	150
Class 13 - 1100 lbs. Super Stock	200
Class 14 - 1100 lbs. 20 hp., 4500 rpm	200
Class 15 - 1100 lbs Sport Stock Twin	200
Class 16 - 1100 lbs. 12 hp.	150

First	Second	Third	Fourth	Fifth
\$33	\$27.50	\$22	\$16.50	\$11

FARM TRACTOR RULES:

1. Each contestant will be allowed two attempts or 75' to start the sled. Track length will be 300' long.
2. *The drawbar must be stationary in all directions, shall be no higher than 20" and extend at least 20" from center of rear axle to hitch point. No two-point or three-point hitch drawbars allowed.
3. Wheelie bars required. They should be strong enough to support the weight of the tractor.
4. Drivers must supply their own clevis or hitch ring with at least a 3" diameter hole.
5. Any tractor which is entered must choose pace or non pace and stay in that class. An open class may not be entered in a stock class, antique class or vice-versa. Tractors with truck engines must pull exhibition only. Classes with pace tractor, puller must stay behind the front of the rear tire of pace tractor.
6. Only one turbocharger is allowed on any tractor and must be adequately shielded or have factory manufactured shield.

7. Front weights must be factory made and properly secured to appropriate brackets forward of front axle, tractors may use homemade brackets.

No loose weights allowed.

8. *Wheel weights and well-casing brackets shall not extend more than 12" from tires. Suitcase weights may be secured to a sturdy bracket on rear of tractor. Weights must not extend above overall height of tires or 6" behind furthest rear point of tires.

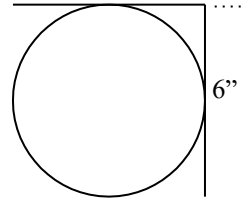

9. Tractors may use "belly bar" brackets for securing suitcase weights ahead of the rear axle.

10. NO CLASS WILL BE RUN MORE THAN ONCE AND ALL RULES WILL BE STRICTLY ENFORCED!!

11. Classes with over 20 entries will pay back 10 places.

12. Only contestants in class may protest that class. No protest will be considered after class is finished.

STOCK FARM TRACTORS:

1. All stock tractors will be pulled against a pace tractor. Any tractor going faster than the pace tractor will be disqualified.
2. Stock tractors may use cut or sharpened tires.
3. Wheelie Bars Mandatory

Wheelie Bar Rules and Pictures:

All tractors **MUST BE EQUIPPED** with wheelie bars strong enough to support the weight of the tractor. Must be made of min. 3/8" material, bottom of pad to track must be 10" max, rear of wheelie bars to be even with back of rear tires. **NO JUNK.**

Tractors with inadequate wheelie bars will not be allowed to pull.

Wheelie bars will not be attached to moveable hitch arms. **Officials will check all wheelie bars.**

IF NOT SAFE AT CHECK IN A CLEVIS WILL BE USED

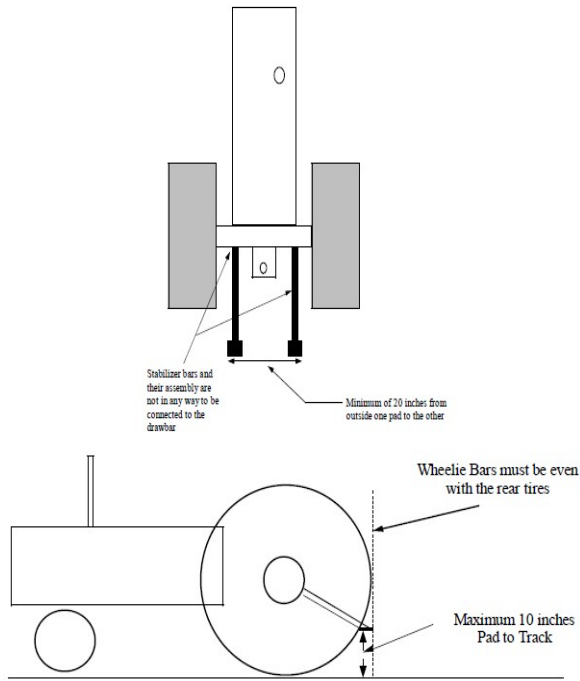

Antique Farm Classes

3750 lbs. 3 mph. 6500 lbs. 3 mph
 4500 lbs. 3 mph 7500 lbs. 4 mph
 5500 lbs. 3 mph 9000 lbs. 4 mph
 10500 lbs, 4 mph

5500 lbs. Powder Puff (pace)

5500 & 6500

Non Pace w/cut Tires w/18.4 Tires Option

PRIZES

First	Second	Third	Fourth	Fifth
\$100.00	\$75.00	\$65.00	\$50.00	\$35.00

New Rules:

1. 4 Wheel Drives allowed but can not be used in 4 Wheel Drive
2. Mandatory for Non-Pace- Blankets and Wheelie Bars
3. Wheelie Bars Mandatory

Stock Farm Classes will be Wednesday morning
All pace classes are 6mph and non pace are 12mph

5500 lbs. 6 mph. 9500 lbs. 6 mph
 5500 lbs. non-pace
 6500 lbs. 6 mph 9500 lbs. non-pace
 6500 lbs. non-pace 10500 lbs. 6 mph
 7500 lbs. pace 10500 lbs. non-pace
 7500 lbs non-pace 12500 lbs. non-pace
 8500 lbs. 6 mph. 12500 lbs. pace
 8500 lbs. non-pace 14500 lbs. 6 mph pace

Jumbo 6mph no dual add the following:
 Must have cab or wheelie bars

All Non Pace Tractors must have emergency shut off in rear of tractor that can be hooked to the pulling sled.

ANTIQUÉ FARM TRACTORS:
Will be Thursday

1. Tractors in these classes must be from 1964 and older, with serial number readily visible for inspection.
2. All tractors will run at 3 M.P.H. with a pace tractor.
3. Tire size limits of 15.5 x 38 on row crop tractors for 4500 and 5500 antique and 6500.
4. Any size tire allowed for 7500 lbs. and 9000 lbs. antique.
5. No cut or altered tires allowed.
6. No Turbo's
7. Wheelie Bars Mandatory

**ORDER OF PULL
SIGN-UP STARTS AT 9 A.M. SHARP!!
PULL STARTS AT 9:30 A.M. SHARP!!**

**NO ENTRY WILL BE ACCEPTED AFTER
OFFICIAL START OF CLASS!!**

Thursday – 9:30 a.m. – Antique Farm Tractor Classes

One sled, light to heavy, powder puff follows pace pulls. In case of a tie, the purse will be split and a coin flipped for the ribbon.

Thursday – 9:30 a.m. Stock -

Pace	Non-Pace
5,500	5,500
6,500	6,500
7,500	7,500
8,500	8,500
9,500	9,500
10,500	10,500
12,500	12,500
14,500	14,500

STOCK TRUCK RULES

1. Drivers must reside in Delaware County and have a valid NYS driver's license.
2. Valid registration.
3. Valid inspection sticker and insurance card
4. Seat belts to be used during pull.
5. Street legal DOT approved tires ONLY.
6. No fuel other than pump gas.
7. Factory installed transmission (no shift kits).
8. Weights to be added behind cab and securely fastened, if lost, you are disqualified.
9. 26" hitch height or lower.
10. Stock suspension, no blocking.
11. Boxes to be street legal and usable.
12. **Standard clevis and pin or other suitable hitching ring with 3" min. I.D. to be on truck. Lift kits are legal.**
13. Headers with street legal mufflers allowed.
14. Trucks pulled in this class cannot pull in any other class.

15. Factory installed engine.
16. Hitches fastened securely.
17. No driver will be allowed to participate while under the influence of drugs, alcohol or any medications that impair abilities.
18. Disqualification can come at any time.
19. If breakdown occurs and broken part or parts fall on track, that will be your measured distance where flagman stops you.
20. Drivers will be allowed two attempts if the first pull is stopped before 75 feet.
21. Only Driver in truck while pulling.
22. DOT helmet recommended.
23. Decision of the judges is final.
24. No Snow Plows on Trucks Pulling.
25. No front weights on trucks
26. Recommended for Diesels/Mandatory on enhanced – Drive Shaft Loops, Bell Housing and Transmission Blankets
27. Enhanced may run front weight

ENTRY FEE: \$15.00 Per Hook

Payback For Street Trucks

First	\$100.00
Second	\$75.00
Third	\$65.00
Fourth	\$50.00
Fifth & Sixth	\$35.00
Seventh thru Tenth	\$25.00

Wednesday Night 7 pm

Stock Street Diesel Single Wheel Truck

8500 Enhanced Diesel

Altered Farm Tractors

2 Classes each weight w/tire size 20.8& 24.5, Killswitches, Blankets, Wheelie bars and Cage
6500, 8500 and 9500

Saturday AM

Stock Gas Trucks, 6 bolt-6000lb
5.7 or smaller
6000 Street Legal
6800 Street Legal- enhanced
7000 Street Legal
Street Modified Gas Truck

RELEASE

IN CONSIDERATION of being permitted to enter for any purpose any RESTRICTED AREA (herein defined as the areas to which admission by general public spectators is prohibited), or being permitted to compete, officiate, observe, work for, or for any purpose participate in any way in the event, EACH OF THE UNDERSIGNED, for himself, his personal representatives, heirs, and next of kin, acknowledges, agrees and represents that he has, or will immediately upon entering any such restricted areas, and will continuously thereafter, inspect such restricted areas and all portions thereof which he enters and with which he comes in contact and he does further warrant that his entry upon such restricted area or areas and his participation, if any, in the event constitutes an acknowledgement that he has inspected such restricted area and that if, at any time, he is in or about restricted areas and he feels anything to be unsafe, he will immediately advise the officials of such and will leave the restricted area(s):

1. HEREBY RELEASES, WAIVES, DISCHARGES AND COVENANTS NOT TO SUE the promoters, other participants, operators, officials, any persons in any restricted area, sponsors, advertisers, owners and lessees of premises used to conduct the event and each of them, their officers and employees, all for the purposes herein referred to as "releasees", from all liability to the undersigned, his personal representatives, assigns, heirs and next of kin for any and all loss or damage, and any claim or demands therefore on account of injury to the person or property or resulting in death of the undersigned, whether caused by the negligence of the releasees or otherwise while the undersigned is in or upon the restricted area, and/or competing, officiating in, observing, working for, or for any purpose participating in the event.

2. HEREBY AGREES TO INDEMNIFY AND SAVE AND HOLD HARMLESS the releasees and each of them from any loss, liability, damage, or cost they may incur due to the presence of the undersigned in or upon the restricted areas or in any way competing, officiating, observing, or working for, or for any purpose participating in the event and whether caused by the negligence of the releasees or otherwise.

3. HEREBY ASSUMES FULL RESPONSIBILITY FOR AND RISK OF BODILY INJURY, DEATH OR PROPERTY DAMAGE due to the negligence of releasees or otherwise while in or upon the restricted area and/or while competing, officiating, observing, or working for or for any purpose participating in the event.

EACH OF THE UNDERSIGNED expressly acknowledges and agrees that the activities could be dangerous and involve the risk of serious injury and/or death and/or property damage. EACH OF THE UNDERSIGNED further expressly agrees that the foregoing release, waiver and indemnity agreement is

intended to be as broad and inclusive as is permitted by law of the Province or State in which the event is conducted and that if any portion thereof is held invalid, it is agreed that the balance shall, notwithstanding, continue in full legal force and effect.

THE UNDERSIGNED HAS READ AND VOLUNTARILY SIGNS THE RELEASE AND WAIVER OF LIABILITY AND INDEMNITY AGREEMENT, and further agrees that no oral representations, statements or inducements apart from the fore-going written agreement have been made.

BY VOLUNTARILY AFFIXING MY SIGNATURE BELOW, I WARRANT THAT I have read and understood all of the foregoing and state that the statements in my application are true and that the releasees will rely on them in granting me the right to participate in the events sponsored by them at the Delaware County Fairgrounds.



IN WITNESS WHEREOF, I have set my hand and seal this _____ day of _____, 20_____.

Name _____

Address _____

Phone _____

Special Release for Minors

The undersigned parents and/or guardians, for and in consideration of the above-noted BENEFITS and mutual covenants accruing to his ward, and intending to be legally bound, by this release do hereby agree to all provisions contained in the above Release and waive all rights and claims that might accrue through relationship to the above applicant and/or owner or owners or driver and do adopt same as if repeated herein.

Signed _____

Date _____